

3/4" TO 1-1/4" ONLY

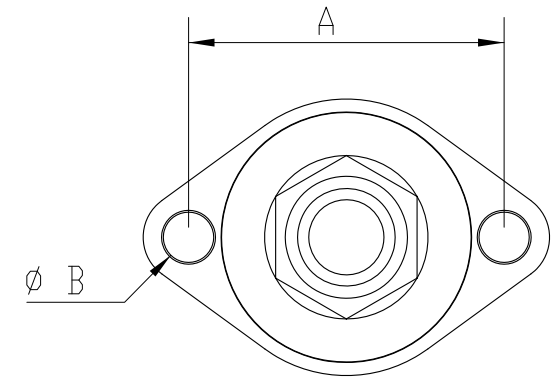

Ref. No.	Description	Material	Qty	Remarks
1	Body	HPb59-3 Brass	1	
2	Ball	HPb58-3 Brass	1	Chrome Plated
3	Endcap	HPb59-3 Brass	1	
4	Seat	PTFE	2	
6	Stem	HPb58-3 Brass	1	
7	Packing	PTFE	1	
8	Handle	Steel	1	Zinc Plated
9	Handle Sleeve	Vinyl	1	
10	Stem O-ring	EPDM	1	
11	Packing Gland Nut	HPb58-3 Brass	1	
12	Flange	HPb59-3 Brass	1	
13	Handle Nut	Steel	1	Zinc Plated
14	Flange Bolt	Q235 Steel, Zinc Plated	2	Not Shown
15	Flange Nut	Q235 Steel, Zinc Plated	2	Not Shown
16	Flange Gasket	NBR	1	Not Shown
17	Tee Handle	Steel	1	Zinc Plated
18	Tee Handle Sleeve	Vinyl	1	

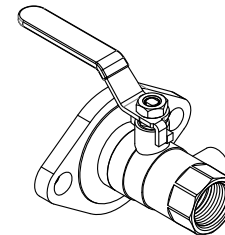

SIZE	ØD	L	E	LT	H	A	ØB
3/4	0.75	3.03	3.62	3.43	2.11	3.13	0.50
1	0.96	3.39	4.33	3.50	2.46	3.13	0.50
1-1/4	1.18	3.66	5.41	3.62	3.05	3.13	0.50
1-1/2	1.46	4.27	5.41		3.15	3.13	0.50

DATE:		BY:	NUMBER:
2011-09-12		PEA	
REV:		APVD:	490_075-150
1			
<p>FNW™</p> <p>4120 NE Columbia Blvd Portland, OR 97211 Phone (503)287-8383 Fax (503)281-9677</p>			
<p>TITLE/DESCRIPTION</p> <p>Figure 490 Brass Body Pump Isolation Threaded End Ball Valve w/Rotating Flange</p>			
<p>CONFIDENTIAL AND PROPRIETARY INFORMATION BELONGING TO FNW VALVE. SUBMITTED FOR THE LIMITED PURPOSE OF PROVIDING INFORMATION ON PRODUCTS AND SYSTEMS. BY RECEIVING THIS DOCUMENT, YOU AGREE NOT TO DISCLOSE SUCH INFORMATION TO OTHERS EXCEPT BY WRITTEN PERMISSION OF FNW VALVE.</p>			
UNITS:	INCHES	SCALE:	NTS
			PAGE 1 OF 1