

FIGURE 233A 3-WAY BALL VALVE

INTRODUCTION

This instruction manual includes installation, operation and maintenance information for the figure 233A 3-way ISO mount, 1000CWP, threaded end (NPT) ball valve.

INSTALLATION

WARNING

To avoid personal injury to your self, fellow workers, or damage to property from release of process fluid, before installation:

- a. Shut off all operating lines to the valve site
 - b. Isolate the valve site completely from the process
 - c. Release process pressure
 - d. Drain the process fluid from the valve site
1. Remove the protective plastic cap from the threaded ends and clean or flush the valve.
 2. Before installing the valve, inspect the valve body port and associated equipment for any damage that may have occurred and for any foreign matter that may have collected in shipping or storage. Make certain the body interior is clean.
 3. Before installing the valve, inspect the pipe line and mating pipe threads, making sure the pipe is free of foreign material and the threads are clean and have no burrs or pits that could cause leakage.
 4. Cycle the valve a couple of times before installation. Valves that are tested to MSS SP-110 may have water trapped between the ball and body cavity. This can be removed by partially opening the valve, exposing the cavity to the through port of the ball. Allow the water to drain out.
 5. Use applicable sealant (e.g. - PTFE tape, high temperature pipe seal, etc.) to seal threaded ends on the pipeline.
 6. To prevent distortion or damage to the valve, do not apply torque through the valve. When tightening the valve, always use a wrench on the end nearest the pipe being tightened. It is preferred that the pipe be screwed into the valve, holding the valve stationary at the end being connected. Do not use the handle to tighten the assembly as damage to the valve may occur.
 7. Clean/flush the pipeline and leak test the system prior to using.
 8. The square stem and notched mounting pad allow the handle to be installed in any of the four quadrants to facilitate a clear stroke path for opening and closing the valve.

OPERATION

1. Ensure that the valve materials are compatible with the service and that the operating characteristics are below the valve maximums.
2. Fluids containing particles or coagulating agents are not acceptable as they can reduce the life of the seats and cause the torque to increase dramatically.
3. Care must be taken if throttling the valve (operation in partially open position). Critical pressure drops and high flow rates can decrease the life of, or damage, the seats. For optimum operation, open/close applications are recommended.
4. Slide the locking plate up the lever before operating. Open and close the valve by turning the handle one-quarter turn (90°).
5. The top of the valve stem has an "L" etched in it. The direction of the "L" indicates the valve's port positions (i.e. – They point to the threaded ends that the ball ports are connecting).
6. Flow plan A pictured to the right, demonstrates that the valve flows in all ports while the lever is in mid position.

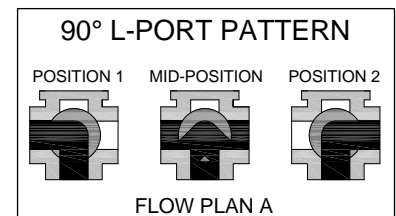

FIGURE 233A 3-WAY BALL VALVE

MAINTENANCE

Valve parts are subject to normal wear and must be inspected and replaced as necessary. Inspection and maintenance frequency depends on the severity of the service conditions. This section includes instructions for packing adjustments, repacking, seat replacement and seating adjustment.

WARNING

To avoid personal injury, fellow workers, or damage to property from release of process fluids, before installation:

- a. Shut off all operating lines to the valve.
 - b. Isolate the valve completely from the process.
 - c. Release process pressure.
 - d. Drain the process fluid from the valve.
1. Ball valves, if properly used, do not require internal lubrication or maintenance. However, a visual inspection should be part of a regular maintenance program. A higher frequency of inspection is recommended for valves operating under extreme conditions. Also, for proper operation it is recommended that the valve be opened and closed at least twice a year.
 2. Before any maintenance, open and close the valve at least once to release the pressure completely from the valve body.
 3. The valve includes live loaded packing that reacts to pressure changes and packing fatigue to reduce the intervals needed for packing adjustments. If the stem packing leaks, remove the operator to access the lower stem nut. Use a long reaching socket over the stem to turn the stem nut clockwise at 30° to 60° intervals until the leak stops. If the stem nut can not be turned clockwise any further, or if the stem packing continues to leak, it will have to be replaced or repaired. **NEVER REPLACE VALVE PACKING WHILE THE VALVE IS IN SERVICE.**
 4. The valve can be rebuilt by using a "Soft Goods" repair kit from FNW.

Disassembly

- A. Place the valve in a vise in one of the end positions. Do not over-tighten the vise or the valve may be deformed.
- B. Remove the first stem nut (13), handle (16), handle gland (14), stop-lock-cap (15), second stem nut (13), belleville washers (12), and gland (11).
- C. With a crescent or strap wrench, remove the end caps (2), seats (4), and the body gaskets (19).
- D. Remove the ball (3) and final seat (4).
- E. Push the stem (5) down through the body (1), and then remove the o-ring (8) and thrust washer (7) from the stem.
- F. Remove the bushing (10) and packing (9) from the body.

Assembly

- A. Rebuild the valve by using all the replacement parts of the rebuild kit.
- B. Ensure that all parts are clean and undamaged.
- C. Assemble the valve in reverse order of the disassembly instructions, except install the packing and bushing after the stem is inserted.

It is recommended to cycle and test the valve prior to resuming service. After reinstallation into the piping system, it may be necessary to adjust the stem nut/packing gland as described in step 3.

FIGURE 233A 3-WAY BALL VALVE

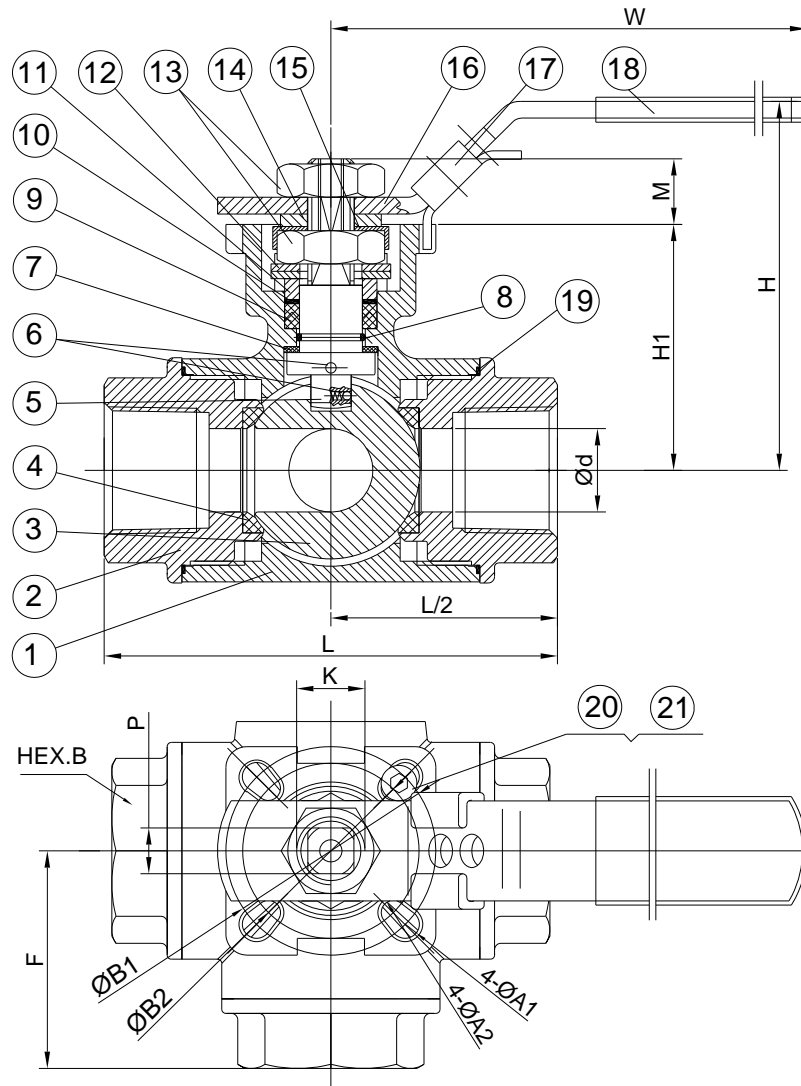

Ref. No.	Description	Material	Qty
1	Body	ASTM A351 Gr. CF8M Stainless	1
2	End Cap	ASTM A351 Gr. CF8M Stainless	3
3	Ball	316SS Stainless	1
4	Seat	RTFE	4
5	Stem	316SS Stainless	1
6	Anti-Static Device	316SS Stainless	2
7	Thrust Washer	PTFE	1
8	O-Ring	FKM	1
9	V-Ring Packing	PTFE	1 Set
10	Bushing	50% Stainless + 50% PTFE	1
11	Gland	316SS Stainless	1
12	Belleville Washer	301SS Stainless	2
13	Stem Nut	ASTM A194-8 Stainless	2
14	Handle Gland	304SS Stainless	1
15	Stop-Lock-Cap	304SS Stainless	1
16	Handle	304SS Stainless	1
17	Lock Device	304SS Stainless	1
18	Handle Sleeve	Vinyl Plastic	1
19	Body Gasket	PTFE	3
20	Stop Bolt	ASTM A193-B8 Stainless	1
21	Stop Nut	ASTM A194-8 Stainless	1

FIGURE 233A 3-WAY BALL VALVE

WARRANTY

- 1. LIMITED WARRANTY:** Subject to the limitations expressed herein, Seller warrants that products manufactured by Seller shall be free from defects in design, material and workmanship under normal use for a period of one (1) year from installation but in no case shall the warranty period extend longer than eighteen months from the date of sale. This warranty is void for any damage caused by misuse, abuse, neglect, acts of God, or improper installation. For the purpose of this section, "Normal Use" means in strict accordance with the installation, operation and maintenance manual. The warranty for all other products is provided by the original equipment manufacturer.
- 2. REMEDIES:** Seller shall repair or replace, at its option, any non-conforming or otherwise defective product, upon receipt of notice from Buyer during the Manufacturer's warranty period at no additional charge. SELLER HEREBY DISCLAIMS ALL OTHER EXPRESSED OR IMPLIED WARRANTIES, INCLUDING, WITHOUT LIMITATION, ALL IMPLIED WARRANTIES OF MERCHANTABILITY AND FITNESS OR FITNESS FOR A PARTICULAR PURPOSE.
- 3. LIMITATION OF LIABILITY:** UNDER NO CIRCUMSTANCES SHALL EITHER PARTY BE LIABLE TO THE OTHER FOR INCIDENTAL, PUNITIVE, SPECIAL OR CONSEQUENTIAL DAMAGES OF ANY KIND. BUYER HEREBY ACKNOWLEDGES AND AGREES THAT UNDER NO CIRCUMSTANCES, AND IN NO EVENT, SHALL SELLER'S LIABILITY, IF ANY, EXCEED THE NET SALES PRICE OF THE DEFECTIVE PRODUCT(S) PURCHASED DURING THE PREVIOUS CONTRACT YEAR.
- 4. LABOR ALLOWANCE:** Seller makes NO ADDITIONAL ALLOWANCE FOR THE LABOR OR EXPENSE OF REPAIRING OR REPLACING DEFECTIVE PRODUCTS OR WORKMANSHIP OR DAMAGE RESULTING FROM THE SAME.
- 5. RECOMMENDATIONS BY SELLER:** Seller may assist Buyer in selection decisions by providing information regarding products that it manufactures and those manufactured by others. However, Buyer acknowledges that Buyer ultimately chooses the product's suitability for its particular use, as normally signified by the signature of Buyer's technical representative. Any recommendations made by Seller concerning the use, design, application or operation of the products shall not be construed as representations or warranties, expressed or implied. Failure by Seller to make recommendations or give advice to Buyer shall not impose any liability upon Seller.
- 6. EXCUSED PERFORMANCE:** Seller will make a good faith effort to complete delivery of the products as indicated by Seller in writing, but Seller assumes no responsibility or liability and will accept no back-charge for loss or damage due to delay or inability to deliver, caused by acts of God, war, labor difficulties, accidents, inability to obtain materials, delays of carriers, contractors or suppliers or any other causes of any kind whatever beyond the control of Seller. Under no circumstances shall Seller be liable for any special, consequential, incidental, or indirect damages, losses, or expense (whether or not based on negligence) arising directly or indirectly from delays or failure to give notice of delay.