

## FIG. 157 HIGH PERFORMANCE BFV'S

### INTRODUCTION

This instruction manual includes installation, operation, and maintenance information for high performance butterfly valves. This manual addresses manually operated valves only (including lever and gear operated) but may contain short notes regarding actuated valves. For complete actuation, options, and accessories information, consult the specific device's manual.

### STORAGE

The valves are shipped with flange covers to protect the disc and sealing surfaces. Do not remove the covers until the time that the valve will be installed. The disc edge is contained within the flange faces of the valves to prevent damage to the sealing area. **Note: If the valves are modified with actuation (such as fail close or fail open actuators), extra care should be given to protect the disc edges from damage.** Valves should be stored in a clean dry area away from heat extremes and corrosive materials. The disc and seat should be protected from possible damage.

### PRE-INSTALLATION

**The following should be read and understood prior to the installation of the valve.**

1. The valves have bi-directional shutoff and can be installed in any position. However, the preferred orientation for optimum service is with the disc face facing upstream, and the disc stem side facing downstream. The valve can be installed with the stem in the vertical, horizontal, or any intermediate position.
2. Lug style valves are rated for full pressure differential on bi-directional dead-end service. Even so, a downstream flange is recommended.
3. 1/16" sheet gaskets of appropriate material may be used. The Flange Bolt Selection Guide is based on the use of 1/16" gaskets. Add 0.12 inches when using metallic spiral wound gaskets. Ensure that the gasket chosen fits the valve's sealing surface face prior to assembly. **NOTE: Do not use thick elastomer type gaskets as line leakage may result.**
4. The valve is made to mount between ANSI Class 150 flanges. Prior to installing the valve, it is important to make sure the ID of the pipe and pipe flanges are large enough to allow the disc edge to swing into the opening without interference. Damage to the disc edge can severely affect the performance of the valve.
5. Prior to installation, make sure that levers, gear operators, or actuators are properly installed and that the stops are properly set for open and close positions. If the valve is supplied with an internal over-travel stop, there may be clearance between the back of the disc and the stop. **WARNING: Do not use the over-travel stop to position the disc or limit the travel of actuators. Doing so may result in damage.**
6. Before installing the valve, ensure that the hand or gear-operator is install such that the position indication matches the position of the valve disc. For lever operated valves, the lever should be in parallel with the disc. For gear-operated valves, the dial indicator on the gear should match the position of the valve disc.
7. Before installing the valve, inspect the valve body port and associated equipment for any damage that may have occurred and for any foreign matter that may have collected in shipping or storage. Make certain the body interior is clean and that the seat facings and disc edge are undamaged.
8. Make sure the valve rating, listed on the identification tag, is sufficient for the service for which the valve will be installed. **WARNING: Personal injury or property damage may result if the valve is installed where service conditions could exceed the valve ratings.**
9. Before installing the valve, inspect the pipe line and mating flanges, making sure the pipe is free of foreign material such as welding residue and the flanges are clean and have no burrs or pits that could cause leakage.
10. If the valve was supplied with an actuator, secondary support may be necessary. Contact FNW for recommendations.
11. Ensure that the pipeline and mating flanges are properly aligned.
12. **WARNING: To avoid spontaneous valve opening, do not remove the locking lever, gear, or other actuator while the valve is under pressure.**

## FIG. 157 HIGH PERFORMANCE BFV'S

13. Flange Bolting Selection Guide – The following bolt and stud selection guide is for installation in ANSI flanges. **CAUTION:** Dimensions provided for flange bolting are intended only as a guide. Bolt lengths may vary due to manufacturing tolerances in valves, gaskets, flange bolts and flanges. **WARNING:** Improper bolt and stud lengths could result in leakage at the flange resulting in death or serious injury.

Wafer Valve with Cap Screws				
Size	D	TPI	L	Qty
3	5/8"	11	4-3/4"	4
4	5/8"	11	5"	8
5	3/4"	10	5-1/2"	8
6	3/4"	10	5-1/2"	8
8	3/4"	10	6"	8
10	7/8"	9	6-1/2"	12
12	7/8"	9	7"	12
14	1"	8	8"	12
16	1"	8	8-1/2"	16
18	1-1/8"	8	9-1/2"	16
20*	1-1/8"	8	10-1/4"	16
			4-1/2"	4
			3-1/4"	4
24*	1-1/4"	8	12"	16
			4-5/8"	4
			3-5/8"	4

Wafer Valve with Studs				
Size	D	TPI	L	Qty
3	5/8"	11	5-3/4"	4
4	5/8"	11	6"	8
5	3/4"	10	6-1/2"	8
6	3/4"	10	6-1/2"	8
8	3/4"	10	7"	8
10	7/8"	9	7-3/4"	12
12	7/8"	9	8-1/4"	12
14	1"	8	9-1/2"	12
16	1"	8	10"	16
18	1-1/8"	8	11"	16
20*	1-1/8"	8	11-1/2"	16
			6-1/8"	4
			4-7/8"	4
			3-1/4"	4
24*	1-1/4"	8	13-1/2"	16
			6-3/8"	4
			5-3/8"	4

Lugged Valve with Cap Screws				
Size	D	TPI	L	Qty
3	5/8"	11	1-3/4"	8
4	5/8"	11	1-7/8"	16
5	3/4"	10	2"	16
6	3/4"	10	2"	16
8	3/4"	10	2-1/4"	16
10	7/8"	9	2-1/2"	24
12	7/8"	9	2-3/4"	24
14	1"	8	3"	24
16	1"	8	3-1/4"	32
18	1-1/8"	8	3-1/2"	32
20*	1-1/8"	8	4"	32
			4-1/2"	4
			3-1/4"	4
			3-1/4"	4
24*	1-1/4"	8	4-5/8"	32
			4-5/8"	4
			3-5/8"	4

Lugged Valve with Studs				
Size	D	TPI	L	Qty
3	5/8"	11	3"	8
4	5/8"	11	3"	16
5	3/4"	10	3-1/4"	16
6	3/4"	10	3-1/4"	16
8	3/4"	10	3-1/2"	16
10	7/8"	9	4"	24
12	7/8"	9	4-1/4"	24
14	1"	8	4-3/4"	24
16	1"	8	5-1/4"	32
18	1-1/8"	8	5-1/2"	32
20*	1-1/8"	8	5-3/4"	32
			6-1/8"	4
			4-7/8"	4
			4-7/8"	4
24*	1-1/4"	8	6-3/4"	32
			6-3/8"	4
			5-3/8"	4

\* The 20" and 24" valves have blind tapped holes near the stem of the valve. Cap screw or stud lengths are indicated for the seat side (shorter length) and other side of the valve.

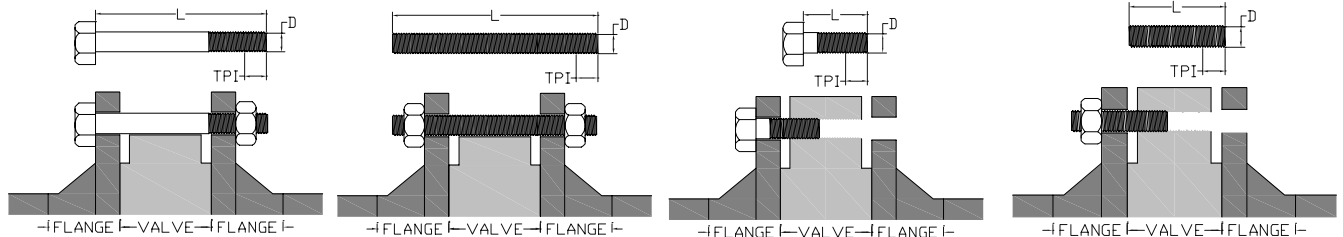

### INSTALLATION

#### WARNING

To avoid personal injury to your self, fellow workers, or damage to property from release of process fluid, before installation:

- a. Shut off all operating lines to the valve site
  - b. Isolate the valve site completely from the process
  - c. Release process pressure
  - d. Drain the process fluid from the valve site
1. With the valve completely closed, make sure the pipe flanges are far enough apart to allow the valve body to be located between the flanges without actually contacting the flange surface (Figure 1-1). Do not install the valve in the open or partial open position (Figure 1-2) or damage to the disc edge may result. If the flanges are not far enough apart, damage to the seat facings can occur (Figure 1-3).
  2. For wafer valves, loosely install the lower flange bolts to form a cradle between the flanges.

## FIG. 157 HIGH PERFORMANCE BFV'S

3. Install the valve between the flanges. NOTE: The preferred orientation for optimum service is with the disc face facing upstream, and the disc stem side facing downstream. Depending on size additional support may be needed. Be sure to leave enough space for flange gaskets.
4. For lugged valves, loosely install the lower flange bolts to form a cradle between the flanges and valve.
5. Install the gaskets, making sure they are centered on the valve facing prior to tightening the flange bolts. Install the remaining flange bolts and hand tighten.
6. With all flange bolts only hand-tightened, make sure the valve is centered between the flanges. Slowly and carefully open and close the valve to insure that there is free and unobstructed disc movement (Figure 1-5).
7. Using the cross-over or star pattern, tighten all bolts evenly.
8. Again, carefully cycle the valve from full open to full close, and then open again to ensure disc clearance (Figure 1-5). Any binding or scraping should be investigated and corrections made.

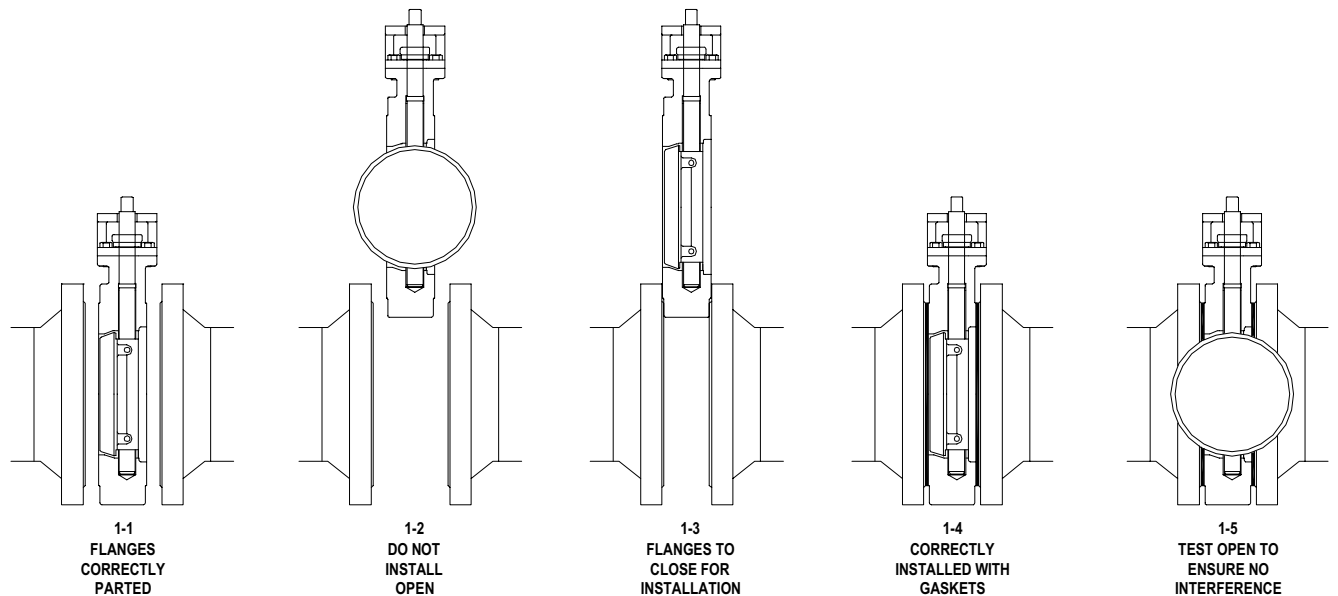

Figure 1

### OPERATION

#### Lever Operated

1. Valves are typically supplied with a locking lever plate. Squeeze the handle and locking lever together, to disengage the locking lever plate. Open and close the valve by turning the handle one-quarter turn (90°).
2. The valve is in the open position when the handle is parallel to the pipe. The valve is in the closed position when the handle is perpendicular to the pipe.

#### Gear Operated

1. The valve is operated by turning the hand wheel in the desired direction. Typically, counter clockwise is towards open, and clockwise is towards closed.
2. Position is indicated by the pointer on the top of the gear operator.

**Note: Do not use cheater bars or lever extenders as damage can occur to internal components.**

## FIG. 157 HIGH PERFORMANCE BFV'S

### TROUBLESHOOTING

The following is intended as a guide only.

Trouble	Probable Cause	Remedy
The valve will not seal properly.	The seat and/or disc are worn or damaged.	Replace worn parts.
	Foreign matter is present between seat and disc.	Operate several times to wipe clean.
	Operator stops are not set properly.	Adjust stops to proper setting.
The valve is hard to operate (Gear or Actuator).	Operator is not installed Properly.	Reinstall operator in proper alignment with valve stem.
The valve will not open.	Disc hits on ID of pipe.	Check for proper pipe clearance and flange/pipe compatibility.
The valve is leaking around the stem.	Packing is not tight.	Tighten packing gland bolts.
	Packing is worn out.	Replace packing as needed.
	Stem is damaged.	Disassemble and examine stem for scratches/nicks. Repair or replace as needed.
The valve closes with line flow.	Handle or actuator does not provide proper restraint.	Restrain disc with locking lever handle or actuator.
	The line flow rate is too high.	Choose a larger valve or otherwise reduce flow to diminish effects of dynamic torque.
There is leakage at the flange.	The valve's flange seal surface is damaged.	Repair or replace as needed.
	The flange surfaces are damaged or corroded.	Clean, repair, or replace flanges.
	The flange bore is too large.	Replace with proper flanges.
	The gasket is improperly sized or installed.	Verify that the gasket is the correct size and centered on the valve sealing surface.
Valve does not shut off or will not move. Open/Close indicators do not coincide with valve disc position.	The gear-operator has not been installed properly	Remove the gear operator. Close the valve or ensure it is open 90° from the close position. Reinstall the gear.
Automatic actuator slams valve closed or open.	Speed control valves are not present or need adjustment.	Install and/or adjust speed control valves.
Hard, soft or cracked seat damage is present.	Heat or chemical damage has occurred to seat.	Verify that seat material is compatible to process fluid or correct offending fluid conditions.
The valve will not physically move to the full close position.	There is an obstruction in the pipe line.	Cycle the valve open then closed several times to see if flow will clear the obstruction. Otherwise it may be necessary to disassemble the piping for service.
	The disc is installed upside down.	See step 7 of the assembly instructions to verify proper orientation. Reassemble if necessary.

## FIG. 157 HIGH PERFORMANCE BFV'S

### MAINTENANCE

Under normal operating conditions, these valves do not require periodic maintenance or lubrication. However, valve parts are subject to normal wear and must be periodically inspected and replaced as necessary. Inspection and maintenance frequency depends on the severity of the service conditions. This section includes assembly and disassembly instructions.

#### WARNING

To avoid personal injury to your self, fellow workers, or damage to property, prior to any maintenance, verify the following conditions.

- a. Be sure the line is depressurized and drained.
- b. Be sure of the pipe line media. Proper care should be taken for protection against toxic and/or flammable fluids.
- c. Never remove the valve without an operator (manual or automatic) already attached to the valve shaft.
- d. Never remove the operator from the valve while the valve is in the pipeline under pressure.
- e. Always be sure the disc is in the near closed position before removing the valve.

#### General

The following periodic preventative maintenance practices are recommended for all high performance style butterfly valves.

1. Operate the valve from full open to full close to assure operability.
2. Check flange bolting for evidence of loosening and correct as needed.
3. Inspect the valve and surrounding area for previous or existing leakage at flange faces or stem.
4. Check piping and/or wiring to actuator and related equipment for looseness and correct as needed.

#### High Performance Butterfly Valve Disassembly and Assembly

**DISASSEMBLY** - The following are general disassembly instructions for all high performance style butterfly valves. General assembly diagrams are provided at the end of this document.

1. Materials and number of parts can vary by size and configuration.
2. Make sure a clean area is available to work in and to place disassembled parts.
3. Parts should be protected from dirt, dust, and possible damage.
4. Follow applicable safety practices when removing the valve from service.
5. With the valve slightly open, remove the seat retainer ring (25) by loosening and removing the retainer ring bolts (76). Remove the seat ring (19) from the retainer ring.
6. Remove the lever handle or gear. Reference the section "Operators" for additional information. For other actuators, consult the device's manual.
7. Open the valve. Remove the disc pins (65) by first grinding off the tack welds and then tapping the pins out from the opposite side.
8. Remove the yoke (5) by loosening and removing the yoke bolts (56), then lifting the yoke off the stem (18).
9. Remove the packing assembly by first removing the packing bolts (58) or gland nuts (59). Remove the upper gland flange (08) and gland ring (20).
10. Pull the stem (18) up through the top of the valve, twisting the stem back and forth at the same time. Due to tight tolerances and the size of the valve, it may be necessary to use mechanical means to remove the stem.  
**NOTE: Be sure to support the disc (06) during this process. Do not allow the disc to fall. Protect the disc and disc washers (64) from damage.**
11. Remove the lower stem bearing (73-1) and disc spring (79) from the lower channel in the body (01).
12. For 8" and larger valves, remove the lower gland flange (08-1) by first removing the lower gland bolts (76-1). Next, remove the flange gasket (98) and disc spring (79).

## FIG. 157 HIGH PERFORMANCE BFV'S

13. For 14" and larger valves, remove the lower stem (18-1). If the disc (06) is still present, turn it 180° from the seat side and then remove it by lifting up and out to gain access to the lower stem. Then remove the lower stem bearing (73-1).
14. With the (upper) stem removed, remove the packing (97), spacer (23), and stem bearing (73) from the stem channel.

ASSEMBLY - The following are general assembly instructions for all high performance style butterfly valves. General assembly diagrams are provided at the end of this document.

1. Materials and number of parts can vary by size and configuration.
2. Make sure that all components are present and undamaged prior to assembly.
3. Make sure a clean area is available to work in and to place disassembled parts.
4. Parts should be protected from dirt, dust, and possible damage.
5. For 6" and smaller valves, insert the disc spring (79) into the lower stem channel in the body (01).
6. Install the upper (73) and lower stem bearings (73-1) into the stem channel on the body (01) and make sure they are seated at the end of the channel.
7. **The valve uses a double offset disc configuration. When looking at the back of the disc (06), the center of the stem hole does not run down the middle of the disc, but is slightly to one side. Measure the two sides of the disc. The shorter side is the side that will be closest to the over travel stop (the stop on the inside of the body port) when the valve is in the closed position. The valve will not function properly if the disc is not correctly oriented during assembly.**
8. While supporting the disc (06) in its typically closed position, insert the stem (18) through the top of the valve and down through the disc washer (64), into the disc, and then through the lower disc washer. Align the pin holes in the stem and disc. **NOTE: The pin holes are tapered so one side is smaller than the other. Be sure the correct side is matched on stem and disc or the pins will not fit properly.**
9. For 14" and larger valves, insert the lower stem (18-1) in through the bottom of the body (01), through the lower disc washer (64), and into the disc (06), making sure the pin holes are aligned as noted in step 6.
10. Insert the tapered disc pins (65) into the holes on the disc (06) by inserting the smaller diameter end of the pin into the larger of the pin holes. Once in, lightly tap the pins to ensure they are well seated. Tack weld the pins in place.
11. Over the stem (18), install the spacer (23), and then the packing (97). **NOTE: The packing is chevron style. Make sure the v-notches fit into each other to create a single packing stack.**
12. Over the stem (18), install the gland ring (20), followed by the gland flange (08). Secure with packing bolts (58) and nuts (59) if applicable. Hand-tighten, then tighten the packing bolts or nuts 1/4 to 1/2 turn further.
13. For 8" and larger valves, install the disc spring (79), lower flange gasket (98), and lower gland flange (08-1) into the bottom of the valve and secure with the lower gland bolts (76-1). Tighten the lower gland bolts.
14. Over the stem (18), install the yoke (05) and secure with the yoke bolts (56). Tighten the yoke bolts.
15. Install the seat ring (19) into the seat retainer ring (25). With the valve slightly open, install the seat assembly into the valve and secure with the retainer ring bolts (76). Tighten all retainer ring bolts evenly.
16. Reinstall the stem lever handle or gear. Reference the section "Operators" for additional information. For other actuators, consult the device's manual.
17. Stroke the valve several times to verify proper operation and stop settings.
18. Once the valve is installed in service, it may be necessary to adjust the packing.

### Packing Adjustments

1. Inspect the packing area to ensure full compression, tight bolting, and no leakage.
2. Should there be a packing leak, turn the packing bolts (58) or nuts (59) evenly at 1/4 turn increments until the leakage stops.

## FIG. 157 HIGH PERFORMANCE BFV'S

### Operators

The following details the assembly of locking lever handles or gear actuators.

#### Levers (3" to 6" valves)

1. Install the locking lever plate (66) over the stem and secure with bolts (76-2) and lock washers (64-1).
2. Install lever (13) over stem and tighten set screw.
3. Install the lever flat washer (64-3), lock washer (64-4), and bolt (76-3).
4. Ensure that the close position of the lever closes the valve and tighten all bolts.

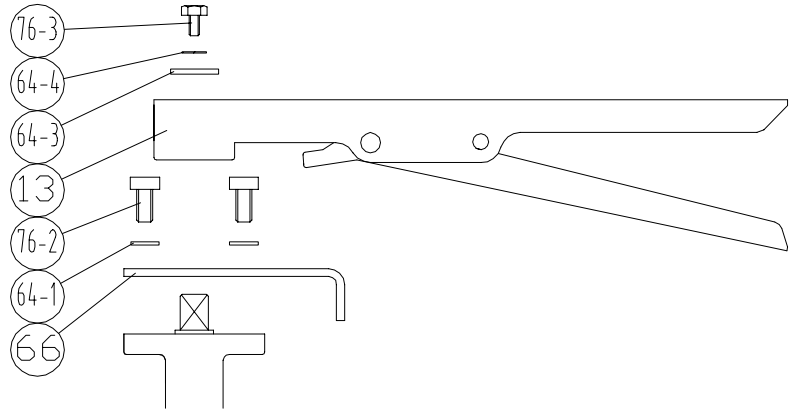

#### Gears (8" to 24" valves)

1. The hand wheel shaft of the gear can be mounted parallel or perpendicular to the pipe line.
2. Make sure the gear position matches the position of the valve. Position is indicated on the top plate of the gear.
3. If there is a make-up sleeve for the stem, place it over the stem at this time.
4. Set the gear (26) on the stem and secure with bolts (82).
5. Ensure that the disc is fully closed when the gear-operator is in the closed position.
6. Adjust stops on gear as needed. Facing the stops, the bolt on the right is the close stop; the bolt on the left is the open stop. Adjust a stop by first loosening the bolt's locking nut. Turn the bolt CW to lessen travel and CCW to increase travel. Retighten the locking nut.

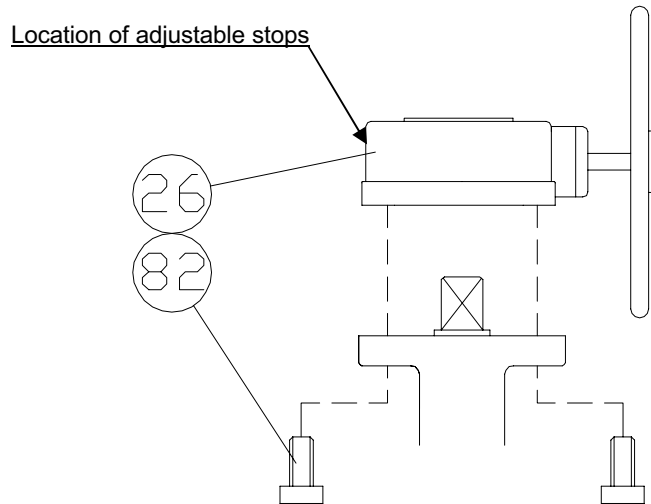

## FIG. 157 HIGH PERFORMANCE BFV'S

### ASSEMBLY VIEW

The following assembly view shows general construction of the high performance butterfly valve and is provided as reference for assembly and disassembly. For specific materials, component quantities and component location, consult the valve dimensional drawings.

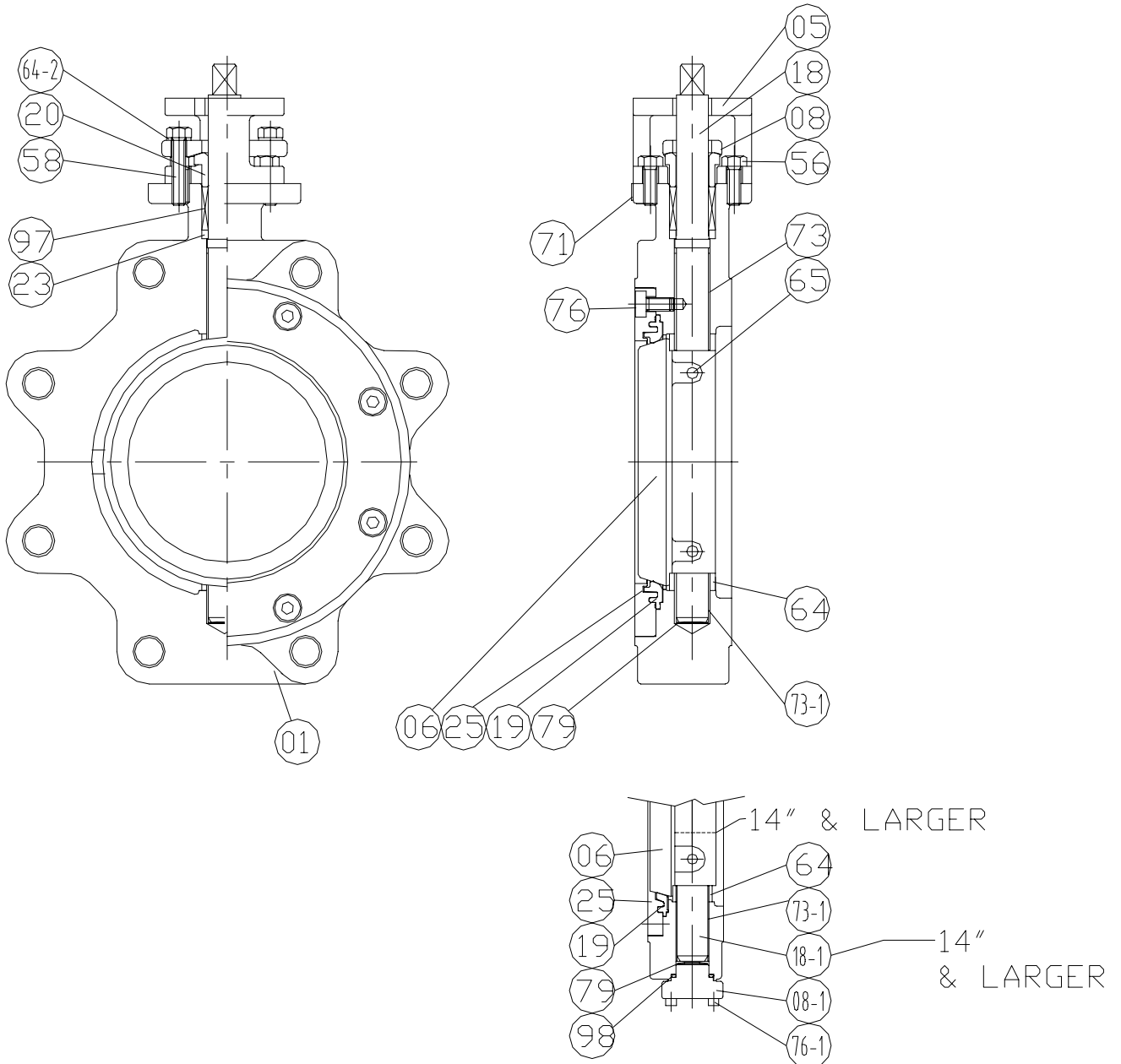

## FIG. 157 HIGH PERFORMANCE BFV'S

### FLOW COEFFICIENTS

The size of butterfly valve used for control purposes should be calculated on the basis of the operating characteristics. In order to achieve optimum control, the flow coefficients (Cv, Kv) below need to be considered.

SIZE	DISC OPENING																	
	10°		20°		30°		40°		50°		60°		70°		80°		90°	
	Kv	Cv	Kv	Cv	Kv	Cv	Kv	Cv	Kv	Cv	Kv	Cv	Kv	Cv	Kv	Cv	Kv	Cv
3	7	8	13	15	24	28	37	43	53	61	82	95	118	137	134	156	147	170
4	16	19	30	35	56	65	87	101	124	144	192	223	278	322	317	368	345	400
5	27	31	49	57	91	106	141	164	202	234	312	362	451	523	516	598	560	650
6	38	44	70	81	129	150	200	232	285	331	442	513	639	741	729	846	793	920
8	82	95	151	175	280	325	435	505	621	720	961	1,115	1,388	1,610	1,586	1,840	1,724	2,000
10	127	147	233	270	433	502	672	780	959	1,112	1,485	1,723	2,144	2,487	2,451	2,843	2,664	3,090
12	176	204	324	376	603	699	936	1,086	1,334	1,548	2,066	2,397	2,984	3,462	3,410	3,956	3,707	4,300
14	209	242	384	445	713	827	1,108	1,285	1,579	1,832	2,447	2,838	3,532	4,097	4,037	4,683	4,388	5,090
16	282	327	519	602	964	1,118	1,497	1,737	2,135	2,477	3,307	3,836	4,774	5,538	5,457	6,330	5,931	6,880
18	381	442	702	814	1,303	1,511	2,024	2,348	2,886	3,348	4,470	5,185	6,454	7,487	7,376	8,556	8,017	9,300
20	465	539	856	993	1,590	1,844	2,471	2,866	3,522	4,086	5,455	6,328	7,877	9,137	9,002	10,442	9,784	11,350
24	762	884	1,403	1,628	2,606	3,023	4,049	4,697	5,772	6,696	8,940	10,370	12,908	14,973	14,752	17,112	16,034	18,600

Cv is the volume of water in U.S. gallons per minute that passes through the valve at a pressure drop of 1 PSI at 68°F. Cv is in imperial units; in metric units, the same coefficient (often called the Flow Factor) is Kv and corresponds to the flow rate of water in cubic meters (m<sup>3</sup>) per hour at a pressure drop of 100kPa (1 bar) at 20°C. The approximate corresponding formulas for flow are:

$$Q = C_v \times \sqrt{\frac{\Delta P \times 62.4}{D}}$$

Where:

- Q = Valve flow rate in gallons per minute (USGPM)
- P = Pounds per square inch (PSI) pressure drop across the valve
- 62.4 = Conversion factor for fluids computed in relation to water
- D = Density of fluids in pounds per cubic foot

$$Q = K_v \times \sqrt{\frac{\Delta P \times 1000}{D}}$$

Where:

- Q = Valve flow rate in cubic meters per hour (m<sup>3</sup>/h)
- P = pressure drop across the valve in Bar
- 1000 = Conversion factor for fluids computed in relation to water
- D = Density of fluids in kilograms per cubic meter (kg/m<sup>3</sup>)

The relationship between Cv and Kv, expressed in the above mentioned unit of measure, is as follows:

$$C_v = 1.16 \times K_v$$

## **FIG. 157 HIGH PERFORMANCE BFV'S**

### **WARRANTY**

- 1. LIMITED WARRANTY:** Subject to the limitations expressed herein, Seller warrants that products manufactured by Seller shall be free from defects in design, material and workmanship under normal use for a period of one (1) year from installation but in no case shall the warranty period extend longer than eighteen months from the date of sale. This warranty is void for any damage caused by misuse, abuse, neglect, acts of God, or improper installation. For the purpose of this section, "Normal Use" means in strict accordance with the installation, operation and maintenance manual. The warranty for all other products is provided by the original equipment manufacturer.
- 2. REMEDIES:** Seller shall repair or replace, at its option, any non-conforming or otherwise defective product, upon receipt of notice from Buyer during the Manufacturer's warranty period at no additional charge. SELLER HEREBY DISCLAIMS ALL OTHER EXPRESSED OR IMPLIED WARRANTIES, INCLUDING, WITHOUT LIMITATION, ALL IMPLIED WARRANTIES OF MERCHANTABILITY AND FITNESS OR FITNESS FOR A PARTICULAR PURPOSE.
- 3. LIMITATION OF LIABILITY:** UNDER NO CIRCUMSTANCES SHALL EITHER PARTY BE LIABLE TO THE OTHER FOR INCIDENTAL, PUNITIVE, SPECIAL OR CONSEQUENTIAL DAMAGES OF ANY KIND. BUYER HEREBY ACKNOWLEDGES AND AGREES THAT UNDER NO CIRCUMSTANCES, AND IN NO EVENT, SHALL SELLER'S LIABILITY, IF ANY, EXCEED THE NET SALES PRICE OF THE DEFECTIVE PRODUCT(S) PURCHASED DURING THE PREVIOUS CONTRACT YEAR.
- 4. LABOR ALLOWANCE:** Seller makes NO ADDITIONAL ALLOWANCE FOR THE LABOR OR EXPENSE OF REPAIRING OR REPLACING DEFECTIVE PRODUCTS OR WORKMANSHIP OR DAMAGE RESULTING FROM THE SAME.
- 5. RECOMMENDATIONS BY SELLER:** Seller may assist Buyer in selection decisions by providing information regarding products that it manufactures and those manufactured by others. However, Buyer acknowledges that Buyer ultimately chooses the product's suitability for its particular use, as normally signified by the signature of Buyer's technical representative. Any recommendations made by Seller concerning the use, design, application or operation of the products shall not be construed as representations or warranties, expressed or implied. Failure by Seller to make recommendations or give advice to Buyer shall not impose any liability upon Seller.
- 6. EXCUSED PERFORMANCE:** Seller will make a good faith effort to complete delivery of the products as indicated by Seller in writing, but Seller assumes no responsibility or liability and will accept no back-charge for loss or damage due to delay or inability to deliver, caused by acts of God, war, labor difficulties, accidents, inability to obtain materials, delays of carriers, contractors or suppliers or any other causes of any kind whatever beyond the control of Seller. Under no circumstances shall Seller be liable for any special, consequential, incidental, or indirect damages, losses, or expense (whether or not based on negligence) arising directly or indirectly from delays or failure to give notice of delay.