

LOW LEAD COMPLIANT 2 PC 600 WOG BALL VALVE

Features:

- 600 WOG
- 150 WSP
- Full Port
- NSF 61 Annex G Approved
- Meets MSS SP-110 Standards
- Blow-out Proof Stem
- Adjustable Packing
- Threaded NPT Ends Per ANSI B 1.20.1 (Figure X420)
- Sweat Ends Per ANSI B 16.18 (Figure X421)
- 100% Electronically Tested in Open and Closed Position at 80 PSI
- Optional Lock Lever *
- Optional Stem Extension
- Optional Tee Handle (to 1")
- Optional Oval Handle
- Optional Memory Stop



Conforms to California law AB 1953 requirements for lead free content.

Note: Lead free refers to the wetted surface of pipe, fittings and fixtures in potable water systems that have a weighted average lead content ≤ 0.25%.
Source: California Health and Safety Code (116875).

OPTIONS



Lock Lever



Stem Extension



Tee or Oval Handle



Memory Stop

Figure Number Matrix

FNW X420 Size		Kit Codes (Order Separately)		
END CODE	SIZE CODE	LOCKING LEVER*	EXTENSIONS	MEMORY STOPS
NPT = 0	1/2 = D	1/2 = FNW420LHKBD	1/2 = FNW420SEBD	1/2 = FNW420MSKBD
SWEAT = 1	3/4 = F	3/4 - 1 = FNW420LHKFG	3/4 - 1 = FNW420SEFG	3/4 - 1 = FNW420MSKFG
	1 = G	1-1/4 - 1-1/2 = FNW420LHKHJ	1-1/4 - 1-1/2 = FNW420SEHJ	1-1/4 - 1-1/2 = FNW420MSKHJ
	1-1/4 = H	2 = FNW420LHKK	2 = FNW420SEK	2 = FNW420MSKK
	1-1/2 = J			
	2 = K			
		* Note: Locking lever kits are of the standard figure 420 yellow sleeve type.	OVAL HANDLES	TEE HANDLES
			1/2 = FNW420OHKBCD	1/2 = FNW420THKBD
			3/4 - 1 = FNW420OHKFG	3/4 - 1 = FNW420THKFG
			1-1/4 - 1-1/2 = FNW420OHKHJ	
			2 = FNW420OHKK	

LOW LEAD COMPLIANT 2 PC 600 WOG BALL VALVE

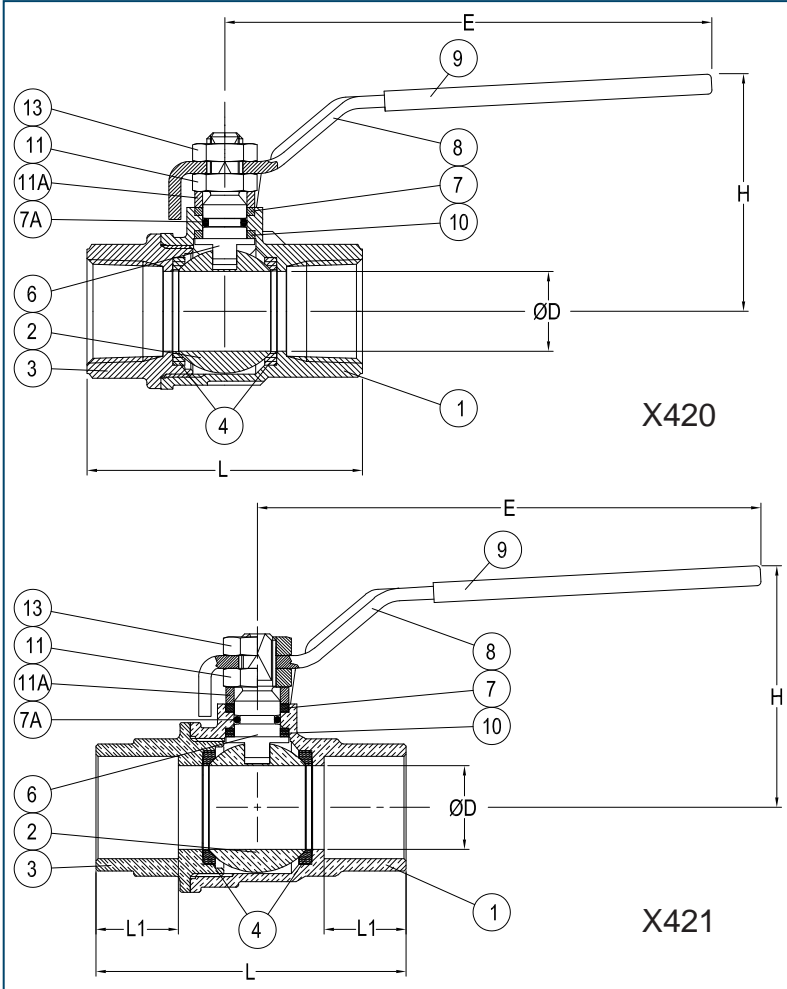

Standard Materials

Ref. No.	Description	Material	Qty
1	Body	Brass CW 510L*	1
2	Ball	Brass CW 510L* (Chrome-Plated)	1
3	End Cap	Brass CW 510L*	1
4	Seat	PTFE	2
6	Stem	Brass CW 510L*	1
7	Stem Packing	PTFE	1 Set
7A	Stem O-Ring	NBR 75 Shore A	1
8	Handle	Steel DD11	1
9	Sleeve	Vinyl	1
10	Thrust Washer	PTFE	1
11	Gland Nut	Steel CL 04	1
11A	Packing Gland	Brass CW 614N UNI 12164	1
13	Handle Nut	Steel CL 04	1

* Chemical Content by Percentage is:

Cu	Ni	Sn	Pb	Fe	Al	Σ% Other	Zn
57 - 59	≤ 0.2	≤ 0.3	≤ 0.2	≤ 0.2	≤ 0.2	≤ 0.1	Remainder

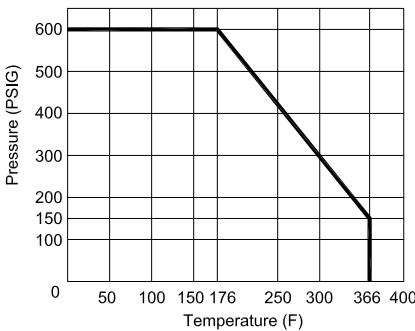

Cv & Weights

Size	Cv	Wt. (Lbs)	
		X420	X421
1/2	19	0.48	0.50
3/4	34	0.79	0.77
1	50	1.22	1.19
1-1/4	103	2.14	2.20
1-1/2	266	3.20	3.24
2	307	4.08	4.21

Dimensions (inches)

Size	ØD	E	H	L		L1
				X420	X421	
1/2	0.59	3.86	1.81	2.44	2.58	0.50
3/4	0.79	4.80	2.28	2.71	3.00	0.75
1	0.98	4.80	2.44	3.07	3.56	0.91
1-1/4	1.26	6.02	3.00	3.42	4.09	0.96
1-1/2	1.57	6.02	3.23	3.89	4.56	1.10
2	1.95	6.38	3.74	4.33	5.45	1.34

DOC: FNWX420-X421 Ver. 11/2009

© 2009 - FNW. All rights reserved.

The FNW logo is a registered trademark of Ferguson Enterprises, Inc.

The contents of this publication are presented for information purposes only, and while effort has been made to ensure their accuracy, they are not to be construed as warranties or guarantees, expressed or implied, regarding the products or services described herein or their use or applicability. All sales are governed by our terms and conditions, which are available on request. We reserve the right to modify or improve the designs or specifications of our products at any time without notice. Always verify that you have the most recent product specifications or other documentation prior to the installation of these products.