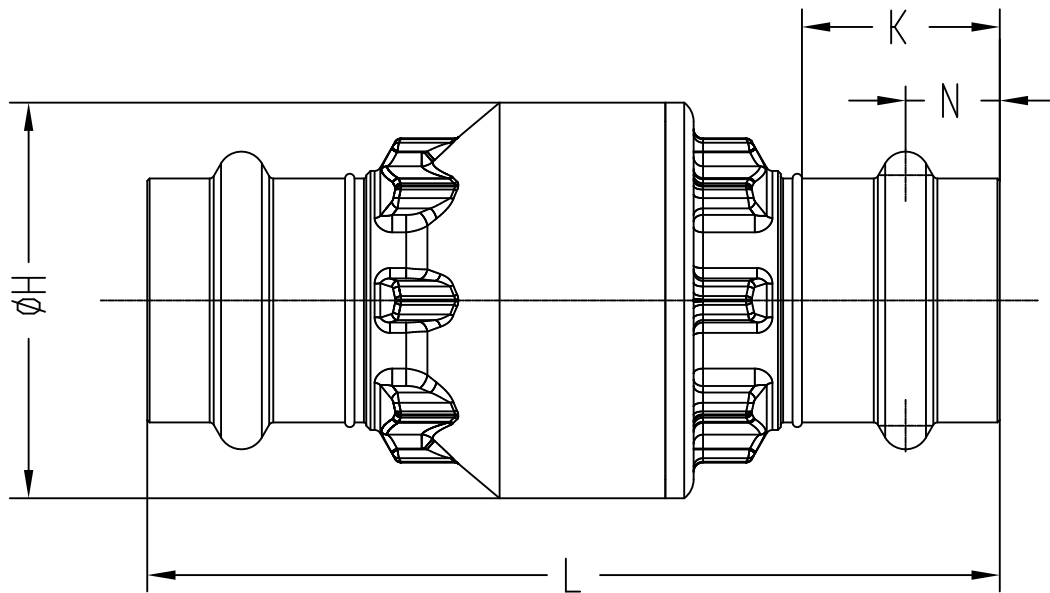

Fig No:

FNWX431





MATERIALS LIST

Ref. No.	Description	Material	Qty
1	Body	Lead Free Brass CW511L	1
2	End Connection	Lead Free Brass CW511L	1
3	Spring	Stainless Steel AISI 302	1
4	Gasket Ring	NBR	1
5	O-Ring	EPDM	2
6	Obstructor	Polyetherimide	1

DIMENSIONS

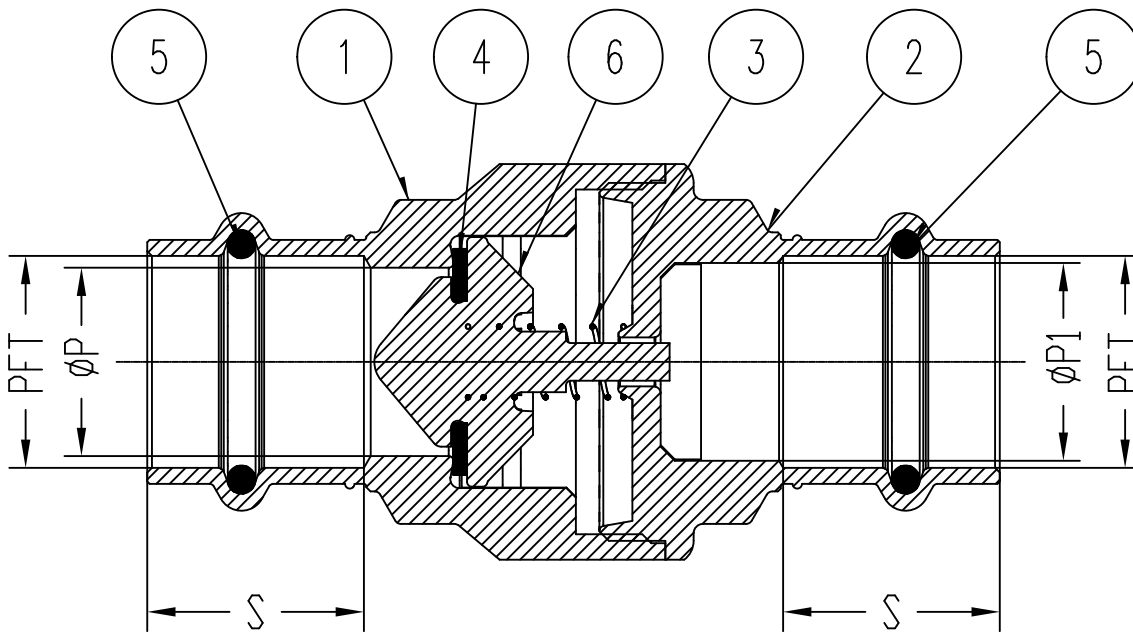
Size	ϕP	$\phi P1$	S	K	N	ϕH	L
1/2	0.59	0.59	0.71	0.67	0.31	1.36	2.99
3/4	0.79	0.83	0.91	0.83	0.39	1.65	3.56
1	0.98	1.07	0.94	0.83	0.39	1.93	3.94
1-1/4	1.26	1.34	1.02	0.83	0.39	2.40	4.09
1-1/2	1.57	1.57	1.42	1.02	0.49	2.87	4.98
2	1.97	1.97	1.57	1.20	0.59	3.46	5.61



CODE	W-003	APPROVED BY.	CHECK BY.	DRAWN BY.	DRAWING NO.	MATERIAL	UNIT	DESCRIPTION
	SIGN						INCH	LF BRASS BODY, HIGH CAPACITY IN-LINE CHECK VALVES, PRESS END, 200 PSI WATER
	DATE			11/24/2006	REVISION	00	SCALE	