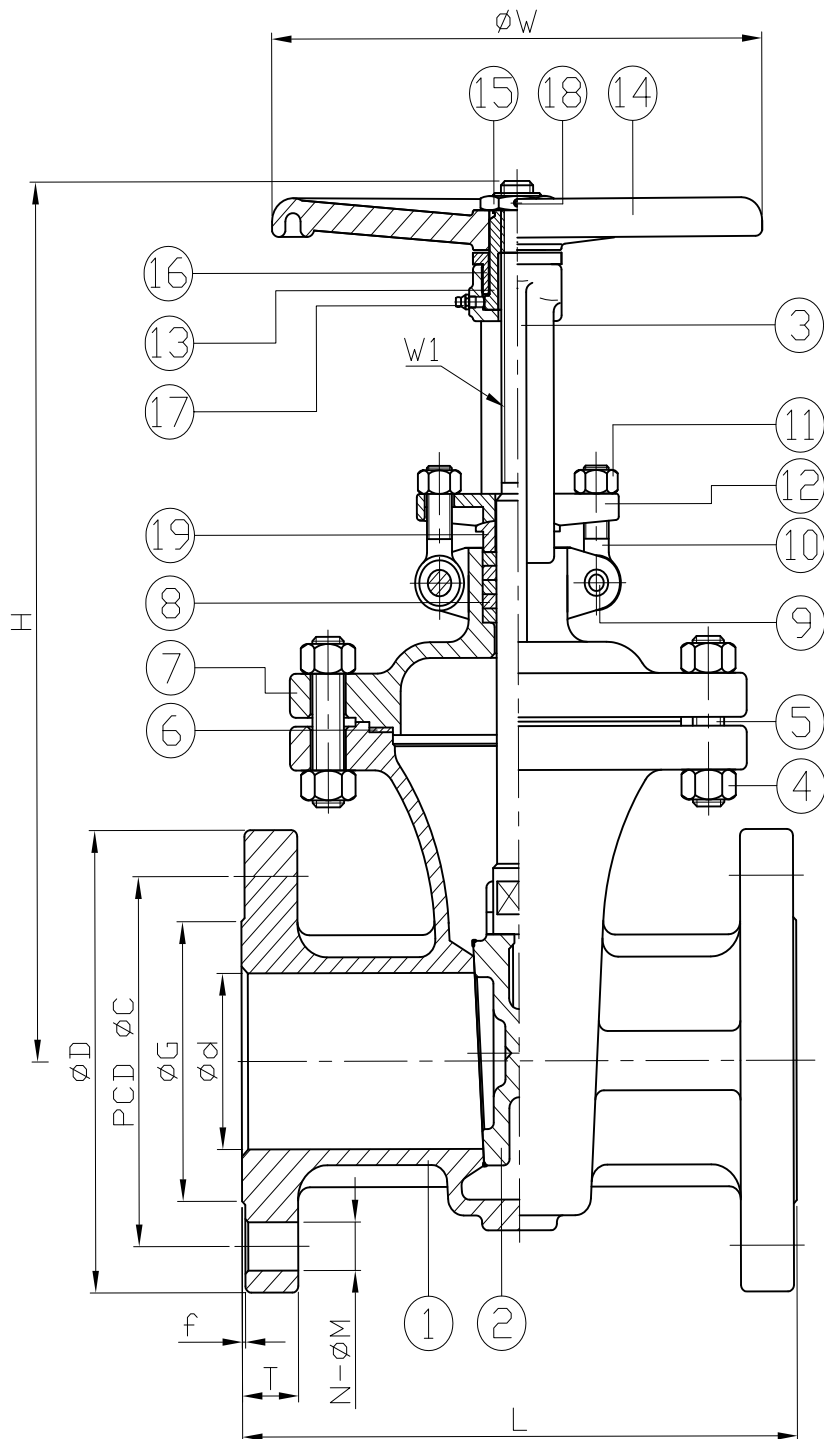

Figure 452A

300# Stainless Steel OS&Y Gate Valve



NOTES:

CF8M Seat is Integral to body
 Investment Cast Body up to 8"
 Design per API 603
 Pressure/Temperature Rating per ANSI B16.34
 Flange Dimensions per ANSI B16.5
 Face to Face Dimensions per ANSI B16.10
 Pressure Tested per API 598

No.	Parts	Material
1	Body	ASTM A351-CF8M
2	Disc	
3	Stem	ASTM A276-316
4	Nut	ASTM A194-8
5	Bolt	ASTM A193-B8
6	Body Seal	PTFE
7	Bonnet	ASTM A351-CF8M
8	Packing	PTFE
9	Pin	AISI 304
10	Gland Bolts	
11	Nut	ASTM A194-8
12	Gland Flange	AISI 304
13	Stem Nut	Brass
14	Handle Wheel	ASTM A536 Gr.60-40-18
15	Handle Nut	AISI 304
16	Gland Nut	
17	Nipple	
18	Socket Set Screws	
19	Gland Ring	

Dimensions (inches) & Weights (lbs)

Size	2	2-1/2	3	4	6	8
d	2.01	2.52	3.15	4.02	5.98	7.99
L	8.50	9.49	11.14	12.01	15.87	16.50
H	12.72	14.57	15.98	19.25	24.76	30.71
W	9.84	9.84	11.81	11.81	15.75	17.72
Flange Dimensions	f	0.08	0.08	0.08	0.08	0.08
	D	6.50	7.48	8.27	10.04	12.60
	G	3.63	4.13	5.00	6.19	8.50
	C	5.00	5.87	6.63	7.87	14.56
	T	0.89	1.02	1.14	1.27	1.46
	N	8.00	8.00	8.00	8.00	12.00
	M	0.75	0.88	0.08	0.88	0.88
Wt. (lbs.)	46.1	56.0	84.9	142.4	253.5	377.0



Title: 300# Stainless Steel Swing Check Valve

Date: 8-25-15

By: Ca

App'd: Mike

Units: In.

Scale: None

Rev Date:

File: 452A.pdf

Model: 452A

DWG NO:

Rev: 0

THIS DRAWING CONTAINS CONFIDENTIAL AND PROPRIETARY INFORMATION OF FNW VALVE AND IS SUBMITTED TO YOU FOR THE LIMITED PURPOSE OF PROVIDING YOU INFORMATION ON PRODUCTS AND SYSTEMS PURCHASED FROM FNW VALVE. BY RECEIVING THIS DOCUMENT, YOU AGREE NOT TO DISCLOSE SUCH INFORMATION TO OTHERS EXCEPT BY WRITTEN PERMISSION.